

Polesyelectromash



Dear colleagues and prospective partners!

Open joint-stock company “Polesyelectromash” invites your cooperation!

Our enterprise was founded in 1975 and it is one of the leading producers of electric motors in Belarus Republic. A long period of development allowed us to create a large industrial enterprise, to concentrate intellectual potential, to prepare qualified personnel, to lay the foundation of technically advanced production process. In 2012 “Polesyelectromash” became a member of “Belarusian metallurgical holding company”.

The enterprise manufactures: three-phase asynchronous motors, single-phase asynchronous motors, special purpose motors, AIRCH-series (new!) motors for electric rail turnout point machines, household purpose cast iron electric hot plates, household centrifugal pumps, centrifugal submersible wastewater pumps, cast iron stoves and , non-ferrous castings.

2AIR80-100-series IE2-efficiency class asynchronous motors were designed. On the average the coefficient of efficiency of these motors is 5% higher than of those that are now serially produced. The introduction of energy efficient motors will provide: a reduction of energy consumption due to higher coefficient of efficiency, a reduction of energy consumption by reducing installed capacity required to operate the equipment with energy-efficient electric drive. (new!)

AIVR-series explosion-proof induction motors with an axis of rotation 80-90mm were designed and put into serial production. For the first time in Belarus explosion-proof motor is made in a cast iron housing which considerable increases its safety and reliability. The motors are designed to operate as electric drive for external and internal installations of dangerously explosive types of production of chemical, gas, oil refinery and others allied industries (new!).

Our technically advanced enterprise “Polesyelectromash” enables us to manufacture products with modern technical features and high functionality. We guarantee quality, reliability, safety.



ELECTRIK MOTORS		
Asynchronous AIP series		
	kw	rpm
AIP71 A2	0,75	3000
AIP 71 B2	1,1	3000
AIP 71 A4	0,55	1500
AIP 71 B4	0,75	1500
AIP 71 A6	0,37	1000
AIP 71 B6	0,55	1000
AIP 80 A2	1,5	3000
AIP 80 B2	2,2	3000
AIP 80 A4	1,1	1500
AIP 80 B4	1,5	1500
AIP 80 A6	0,75	1000
AIP 80 B6	1,1	1000
AIP 90 L2	3,0	3000
AIP 90 LB2	4,0	3000
AIP 90 L4	2,2	1500
AIP 90 LB4	3,0	1500
AIP 90 L6	1,5	1000
AIP 90 LA8	0,75	750
AIP 90 LB8	1,1	750
AIP 100 S2	4,0	3000
AIP 100 S4	3,0	1500
AIP 100 L4	4,0	1500
AIP 100 L6	2,2	1000
AIP 100L2	5,5	3000
AIP 112M2	7,5	3000
AIP 112M4	5,5	1500
AIP 112MA6	3,0	1000
AIP 112MB6	4,0	1000
AIP 112MA8	2,2	750
AIP 112MB8	3,0	750
Multispeed electric motors		
AIP 80 A4/2	1,12	1500
	1,5	3000
AIP 90 L4/2	2,2	1500
	2,65	3000
AIP 90 L6/4	1,32	1000
	1,6	1500
AIP 90 L8/4	0,8	750
	1,32	1500
AIP 100 S8/4	1,0	750
	1,7	1500
For unit construction pump drive		
AIP 80 A2Ж	1,5	3000
AIP 80 B2Ж	2,2	3000
AIP 80 B4Ж	1,5	1500
AIP 90 L2Ж	3,0	3000
AIP 90 L4Ж	2,2	1500

For reduction gears		
AIP90 L2 P3	3,0	3000
AIP90 L4 P3	2,2	1500
AIP90 L6 P3	1,5	1000
AIP90 LA8 P3	0,75	750
AIP90 LB8 P3	1,1	750
Motors with the greater slip		
AIPС 80 A2	1,9	3000
AIPС 80 B2	2,5	3000
AIPС 80 A4	1,32	1500
AIPС 80 B4	1,7	1500
AIPС 80 A6	0,75	1000
AIPС 80 B6	1,25	1000
AIPС 90 L2	3,5	3000
AIPС 90 LB2	4,8	3000
AIPС 90 L4	2,4	1500
AIPС 90 LB4	3,2	1500
AIPС 90 L6	1,7	1000
AIPС 90 LA8	0,9	750
AIPС 90 LB8	1,2	750
AIPС 100 S2	4,8	3000
AIPС 100 S4	3,2	1500
AIR-series single-phase motors		
AИPE 71 A2	0,55	3000
AИPE 71 B2	0,75	3000
AИPE 71 C2	1,1	3000
AИPE 71 A4	0,37	1500
AИPE 71 B4	0,55	1500
AИPE 71 C4	0,75	1500
AИPE 80 A2	1,1	3000
AИPE 80 B2	1,5	3000
AИPE 80 C2	2,0	3000
AИPE 80 C2/S6	2,2	3000
AИPE 80 D2	2,2	3000
AИPE 80 A4	0,75	1500
AИPE 80 B4	1,1	1500
AИPE 80 C4	1,5	1500
AИPE 90 L2	2,2	3000
AIS-series three-phase motors		
AИC 90 S2	1,5	3000
AИC 90 L2	2,2	3000
AИC 90 S4	1,1	1500
AИC 90 L4	1,5	1500
AИC 90 S6	0,75	1000
AИC 90 L6	1,1	1000
AИC 100 L2	3,0	3000
AИC 100 LB2	4,0	3000
AИC 100 LA4	2,2	1500
AИC 100 LB4	3,0	1500
AИC 100 L6	1,5	1000
AИC 100 LA8	0,75	750
AИC 100 LB8	1,1	750

AIS-series multi-speed motors		
AИC 90 S4/2	1,12	1500
	1,5	3000
AИC 100 LA4/2	2,2	1500
	2,65	3000
AИC 100 LA6/4	1,32	1000
	1,6	1500
AИC 100 LA8/4	0,8	750
	1,32	1500
AIVR-series explosion-proof asynchronous motors		
AИВР 80A2	1,5	3000
AИВР 80A4	1,1	1500
AИВР 80A6	0,75	1000
AИВР 80B2	2,2	3000
AИВР 80B4	1,5	1500
AИВР 80B6	1,1	1000
AИВР 90 L2	3,0	3000
AИВР 90 LB2	4,0	3000
AИВР 90 LA4	2,0	1500
AИВР 90 L4	2,2	1500
AИВР 90 LB4	3,0	1500
AИВР 90 L6	1,5	1000
AИВР 90 LA8	0,75	750
AИВР 90 LB8	1,1	750
AИВР 90 L4/2	2,2/2,65	1500/3000
AИВР 90 L6/4	1,32/1,6	1000/1500
AИВР 90 L8/4	0,8/1,32	750/1500
Motors for electric drive axial-flow fan in livestock buildings and poultry premises (poultry houses)		
AИРП 80A6	0,37	1000
AИРП 80B6	1,1	1000
AИРП 80C6	0,75	1000
Motors for railroad electric point machines		
AИРЧ80B4	0,55	1500
AИРЧ80B6	0,3	1000
Energy-efficient motors		
2AИR80A2	1,5	3000
2AИR80B2	2,2	3000
2AИR80A6	0,75	1000
2AИR80B6	1,1	1000
2AИR90L2	3,0	3000
2AИR90L4	2,2	1500
2AИR90L6	1,5	1000
2AИR100S2	4,0	3000
2AИR100L2	5,5	3000
2AИR100S4	3,0	1500
2AИR100L4	4,0	1500
2AИR100L6	2,2	1000

**.Key to Symbols**

xxx	x	xxx	x	x	xxxx	xx	xxxx
1	2	3	4	5	6	7	8

1 – Series name:

A – Asynchronous

И – developed within Interelectro framework

B – explosion-proof

P or C – binding of power capacity to dimensional linkage according to PC3031-71 or CENELEC – DOCUMENT 28/64 standards

П – for microclimate control systems in poultry and livestock buildings Ч

– for railways

2 – Electric modifications:

C – with increased slip;

B – built-in;

E – single-phase with a two-phase winding; 3E

– single-phase with a three-phase winding.

3 – Dimension – rotation axis height, mm: 71, 80, 90, 100, 112**4 –S, M, L – Setting-out size according to frame length**

No letter – unified setting-out sizes for stators A, B, C, D.

5 – Center hub length for stators A, B, C, D

Lack of a letter means that at the setting-out size given (S or L, M), only one central hub length is installed.

6 – Number of engine poles: 2, 4, 6, 8, 4/2, 6/4, 8/4.**7 – Structural variations**

Б –with built-in temperature protection;

P3 – for motor-reducers;

Ж – for monoblock pumps;

П – increased accuracy ;

C – agricultural applications

X2 – chemical modification.

8– Climatic modification: Y1, Y2, Y3, Y5, T2, YXЛ2, YXЛ4, according to all-Union standard 15150.



.MOUNTING TYPE MODIFICATIONS

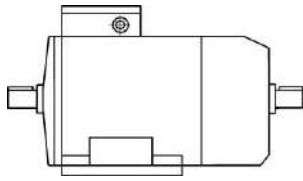

IM 1081(1082)
B3

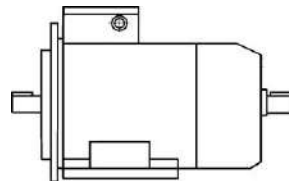

IM 2081(2082)
B35

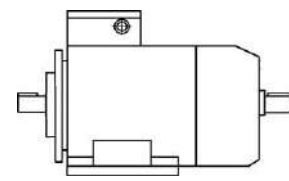

IM 2181(2182)
B34

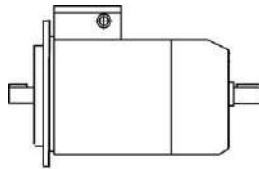

IM 3081(3082)
B5

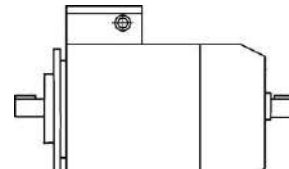

IM 3681(3682)
B14

3. EXECUTION DEPENDING ON THE DEGREE OF PROTECTION

IP 54, IP 55 according to all-Union standard 15150.

First digit is **5** – motor case is dust resistant Second digit is **4** – water splash protection.

5 – water sheet protection.

4. ORDER OF ELECTRICAL MOTORS

To ensure a quick and high-quality execution of your order, please note the following motor specifications on the application from:

- type;
- power kW;
- rotating speed, rpm;
- standard voltage, V;
- network frequency, Hz;
- climatic version
- type of fastening;
- execution depending on the degree of protection;
- special requirements (if necessary).

Example: Motor AIP90L4Y3, 380 V, 50 Hz, IM1081, IP54 (power capacity – 2,2 kW, 1500 rpm).

5. ASYNCHRONOUS ELECTRICAL MOTORS OF AIR SERIES

5.1. Asynchronous three-phase electrical motors of general-purpose modification

Designed for bundling with electric drives of different machinery in all industry and agriculture branches.

Developed for ac network. Power frequency: 50 and 60 Hz, 220-600V voltage, IP54 seal rating (by the order IP55), F insulation class.

- Following motor modifications are possible: with in-built temperature
- protection (Б); of particular accuracy (П); chemically resistant (X2); climatic modification:
-
-



perate climate (Y2, Y3, Y5), cold-temperate (УХЛ2, УХЛ4), tropical (T2), according to all-Union State Standard 15150

Motor overall and linkage dimensions are given in Figure A and Table 1.

Electrical parameters and masses (for IM1081 fulfillment) are given in Table 2.

Figure A

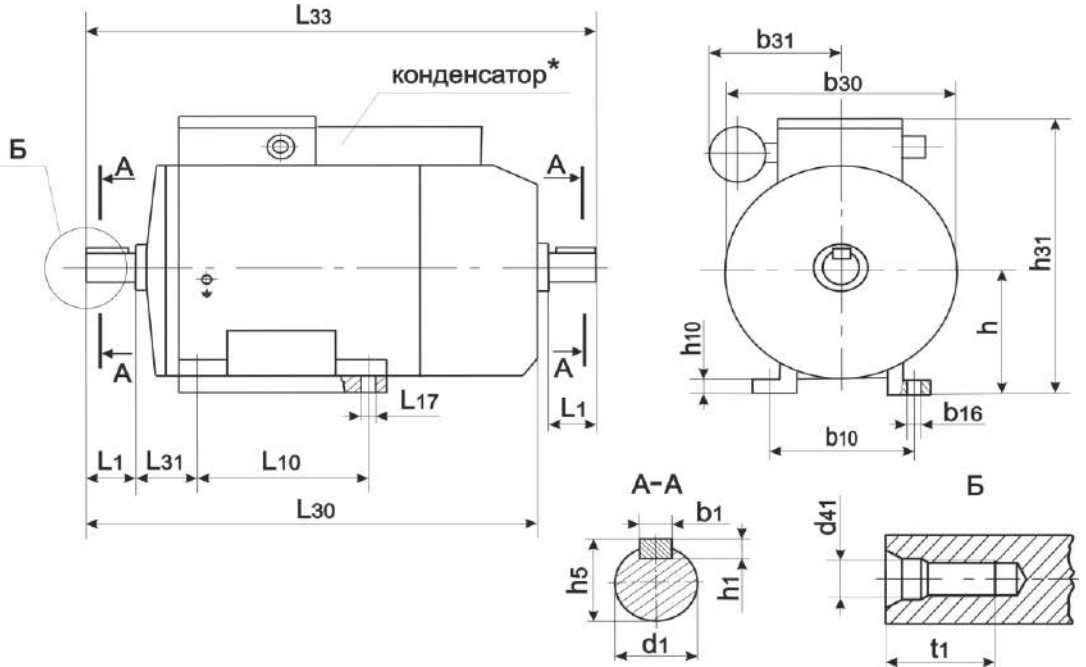

Modification IM108X

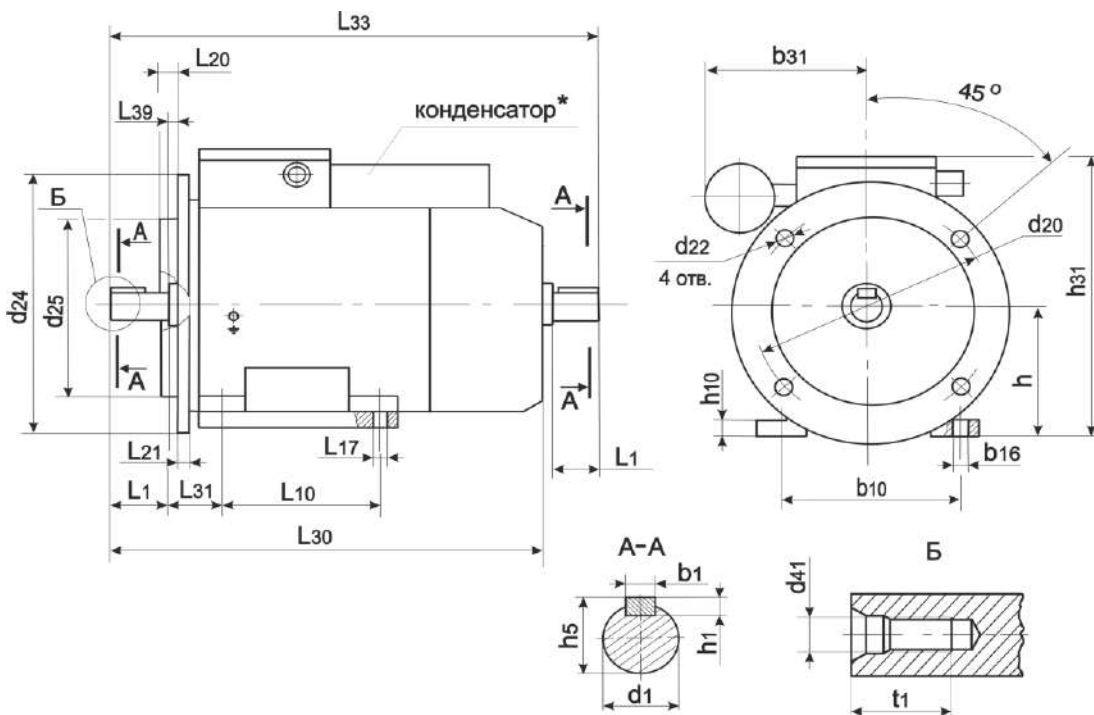

Modification IM208X,
IM218X, IM308X, IM368X

(* for single-phase motors only)



Size index		АИР 71 АИРЕ 71	АИР 80А АИРС 80А АИРЕ 80А	АИР 80В АИРС 80В АИРЕ 80В АИРЕ 80С АИРЕ 80Д	АИР 90 АИРС 90 АИРЕ 90	*АИР 100S *АИРС 100S	*АИР 100L	АИР 100L	АИР 112М
Overall (maximall)									
L30		272,5	296,5	320,5	337	347	367	412	462
L33		316,5	350	374	390	410	430	466	—
b30		160	180	180	200	200	200	212	212
b31		115	115	115	115	—	—	—	—
h31		188	204,5	204,5	230	240	240	258,5	270,5
h37		117	124,5	124,5	140	140	140	—	—
Linkage									
L1		40	50	50	50	60	60	60	80
L10		90	100	100	125	112	140	140	140
L17		7	10	10	10	12	12	12	12
L31		45	50	50	56	63	63	63	70
L39		0	0	0	0	0	0	0	0
b10		112	125	125	140	160	160	160	190
b16		10	12	12	12	16	16	16	16
h		71	80	80	90	100	100	100	112
d1		19	22	22	24	28	28	28	32
d41		M6	M8	M8	M10	M10	M10	M10	M12
t1		16	19	19	22	22	22	22	28
d20	IM2081;IM2082 IM3081;IM3082	165	165	165	215	215	215	215	265
	IM2181;IM2182 IM3681;IM3682	85;115	100; 115; 130	100; 115; 130	115; 130	115; 130; 165	130	130	130; 165
d22	IM2081;IM2082 IM3081;IM3082	12	12	12	15	15	15	15	15
	IM2181;IM2182 IM3681;IM3682	M6; M8	M6; M8; M8	M6; M8; M8	M8; M8	M8; M8; M10	M8	M8	M8; M10
d24	IM2081;IM2082 IM3081;IM3082	200	200	200	250	250	250	250	300
	IM2181;IM2182 IM3681;IM3682	105; 140	146; 146;160	146; 146; 160	140; 164	140; 164; 200	180	180	156; 211
d25	IM2081;IM2082 IM3081;IM3082	130	130	130	180	180	180	180	230
	IM2181;IM2182 IM3681;IM3682	70; 95	80; 95;110	80; 95; 110	95; 110	95; 110; 130	110	110	110; 130
Справочные									
L20	IM2081;IM2082 IM3081;IM3082	3,5	3,5	3,5	4,0	4,0	4,0	4,0	4,0
	IM2181;IM2182 IM3681;IM3682	2,5; 3,0	3,0; 3,0; 3,5	3,0; 3,0; 3,5	3,0; 3,5	3,0; 3,5; 4,0	3,5	3,5	3,5
L21		10	10	10	12	12	14	14	15
b1		6	6	6	8	8	8	8	10
h1		6	6	6	7	7	7	7	8
h5		21,5	24,5	24,5	27,0	31	31	31	35
h10		8	9	9	10	12	12	12	12

* Motors with reduced overall dimensions

b
l
e
1

Electric parameters									
Type	P, kW	Standard rotating frequency, rpm	Coef. of efficiency, %	cos φ	I _n /I _H	M _n /M _n	M _{max} /M _n	M _{min} /M _n	Mass, kg
AIP 71 A2	0,75	3000	77,0	0,8	6,0	2,6	2,7	1,6	10,2
AIP 71 B2	1,1	3000	78,0	0,8	6,0	2,2	2,4	1,6	10,5
AIP 71 A4	0,55	1500	71,0	0,71	5,0	2,3	2,4	1,8	9,7
AIP 71 B4	0,75	1500	74,0	0,78	5,0	2,5	2,6	2,4	10,2
AIP 71 A6	0,37	1000	66,0	0,63	4,5	2,1	2,3	1,6	9,2
AIP 71 B6	0,55	1000	69,0	0,68	4,5	1,9	2,2	1,6	10,8
AIP 80 A2	1,5	3000	82,0	0,85	6,5	2,2	2,6	1,8	13,3
AIP 80 B2	2,2	3000	83,0	0,87	6,4	2,1	2,6	1,8	15,9
AIP 80 A4	1,1	1500	75,0	0,81	5,0	2,2	2,4	1,7	12,8
AIP 80 B4	1,5	1500	78,5	0,80	5,3	2,2	2,4	1,7	14,7
AIP 80 A6	0,75	1000	71,0	0,63	4,0	2,1	2,2	1,6	12,5
AIP 80 B6	1,1	1000	75,0	0,74	4,5	2,2	2,3	1,8	16,2
AIP 90 L2	3,0	3000	84,5	0,85	7,0	2,3	2,6	1,7	20,6
AIP 90 LB2	4,0	3000	86,5	0,86	7,5	2,0	2,4	1,6	23,4
AIP 90 L4	2,2	1500	81,0	0,83	6,0	2,0	2,6	2,0	19,7
AIP 90 LB4	3,0	1500	81,5	0,81	6,5	2,0	2,4	1,7	24,1
AIP 90 L6	1,5	1000	76,0	0,72	5,0	2,0	2,3	1,9	20,6
AIP 90 LA8	0,75	750	72,5	0,71	4,0	1,5	2,0	1,5	19,5
AIP 90 LB8	1,1	750	76,0	0,72	4,5	1,5	2,2	1,5	22,3
AIP 100 S2	4,0	3000	86,5	0,86	7,5	2,0	2,4	1,6	23,6
AIP 100 S4	3,0	1500	81,5	0,81	6,5	2,0	2,4	1,7	25,8
AIP 100 L4	4,0	1500	83,1	0,80	7,0	2,1	2,4	1,6	26,1
AIP 100 L6	2,2	1000	78,0	0,74	6,0	1,9	2,2	1,6	25,1
AIP 100L2	5,5	3000	87,5	0,88	7,5	2,1	2,4	1,6	31,0
AIP 112M2	7,5	3000	87,5	0,89	7,5	2,0	2,2	1,6	37,0
AIP 112M4	5,5	1500	85,0	0,86	7,0	2,0	2,5	1,6	38,5
AIP 112MA6	3,0	1000	83,0	0,72	6,0	2,0	2,2	1,6	35,9
AIP 112MA8	2,2	750	77,2	0,73	4,6	2,1	2,5	1,4	35,3
AIP 112MB6	4	1000	84,5	0,75	6,0	2,0	2,2	1,6	41
AIP 112MB8	3,0	750	76,5	0,72	4,4	2,1	2,4	1,4	40

Energy-efficient motors

2AIR80, 2AIR90, 2AIR100 energy-efficient motors went into serial production at the enterprise in 2013. They are intended for different electric motor driven mechanisms of all the branches of industry and agricultural complex. The motors are powered by alternating current sources such as from power grid. (They are designed to operate from AC power).

Electric motors IE2 efficiency-class according to STB IEC 60034-30-2011. The nominal values of the motors' main parameters are shown in Table 3

Table 3

Type	P, kW	Standard rotating frequency, rpm	Coefficient of efficiency, %	Efficiency	cos φ	M _п /M _n	M _{max} /M _n	M _{min} /M _n	I _п /I _n
2AIR80A2	1,5	3000	81,3	2	0,89	2,2	2,6	1,8	6,5
2AIR80B2	2,2	3000	83,2	2	0,90	2,1	2,6	1,8	6,4
2AIR80A6	0,75	1000	75,9	2	0,67	2,1	2,2	1,6	4,0
2AIR80B6	1,1	1000	78,1	2	0,69	2,2	2,3	1,8	4,5
2AIR90L2	3,0	3000	84,6	2	0,90	2,3	2,7	2,0	7,0
2AIR90L4	2,2	1500	84,5	2	0,84	2,7	2,8	2,2	7,2
2AIR90L6	1,5	1000	80,3	2	0,76	2,6	3,0	2,4	6,0
2AIR100S2	4,0	3000	85,8	2	0,93	2,5	3,5	2,0	8,3
2AIR100L2	5,5	3000	87,0	2	0,94	2,4	3,2	1,65	8,4
2AIR100S4	3,0	1500	85,7	2	0,78	2,5	3,0	2,0	7,0
2AIR100L4	4,0	1500	86,9	2	0,79	2,5	3,0	2,0	7,5
2AIR100L6	2,2	1000	82,2	2	0,80	2,7	3,1	2,0	6,3

5.3. Multispeed electric motors

Designed for machinery drive that require stepped rotation frequency control.

Special modifications comply with general-purpose modification. Overall and linkage dimensions are shown in Figure A and Table 1. Electric parameters and masses (for IM1081 fulfillment) are given in Table 4

Table 4

Type	Electric parameters								Mass, kg
	P, kW	Standard rotating frequency, rpm	Coefficient of efficiency, %	cos φ	I _п /I _n	M _п /M _n	M _{max} /M _n	M _{min} /M _n	
AIP 80 A4/2	1,12	1500	74,0	0,78	5,0	1,9	2,2	1,6	13,1
	1,5	3000	73,0	0,85	5,0	1,9	2,0	1,5	
AIP 90 L4/2	2,2	1500	79,0	0,83	6,0	1,9	2,4	1,6	21,3
	2,65	3000	78,0	0,86	6,0	2,0	2,4	1,5	
AIP 90 L6/4	1,32	1000	74,0	0,68	5,0	2,3	2,5	1,5	22,0
	1,6	1500	74,0	0,85	5,5	1,6	2,1	1,2	
AIP 90 L8/4	0,8	750	62,0	0,55	3,0	1,7	2,0	1,6	20,9
	1,32	1500	75,0	0,84	5,0	1,5	2,0	1,3	
AIP 100 S8/4	1,0	750	64,0	0,53	3,4	1,2	1,8	1,1	22,8
	1,7	1500	78,0	0,87	5,0	1,1	1,8	1,0	

Motors with the greater slip

Designed for machinery drive with long-term lag and for machinery with intermittent working cycle (S3). These motors have greater thread slip at standard load than basic modification, and critical slip equals about 40%. The motors are unified with basic modification. They have the letter «C» after serial name (AIPC). Special modifications comply with general-purpose modification. Electric parameters and masses (for IM1081 fulfillment) are given in Table 5

Table 5

Type	Electric parameters									
	P, kW at S3 40%	Standard rotating frequency, rpm	Coefficient of efficiency, %	cos φ	Critical slip, %	I _п /I _н	M _п / M _н	M _{max} / M _н	M _{min} / M _н	Mass, kg
AIPC 80 A2	1,9	3000	76,0	0,80	40	6,5	2,1	2,2	1,6	13,3
AIPC 80 B2	2,5	3000	76,0	0,86		6,5	2,1	2,2	1,6	15,9
AIPC 80 A4	1,32	1500	69,0	0,80		6,5	2,1	2,2	1,6	12,8
AIPC 80 B4	1,7	1500	71,0	0,82		6,5	2,1	2,2	1,6	14,7
AIPC 80 A6	0,8	1000	67,0	0,73		4,0	2,0	2,0	1,6	12,5
AIPC 80 B6	1,25	1000	66,5	0,73		4,0	2,1	2,1	1,6	16,2
AIPC 90 L2	3,5	3000	80,0	0,86		6,5	2,0	2,2	1,6	20,6
AIPC 90 LB2	4,8	3000	82,0	0,86		7,5	2,0	2,2	1,6	23,4
AIPC 90 L4	2,4	1500	77,0	0,81		6,0	2,2	2,2	2,0	19,7
AIPC 90 LB4	3,2	1500	77,0	0,80		6,0	2,0	2,2	1,6	24,1
AIPC 90 L6	1,7	1000	71,0	0,72		6,0	2,0	2,2	1,6	20,6
AIPC 90 LA8	0,9	750	69,0	0,72		3,5	1,6	1,9	1,5	19,5
AIPC 90 LB8	1,2	750	67,0	0,72		3,5	1,6	1,9	1,5	22,3
AIPC 100 S2	4,8	3000	82,0	0,86		7,5	2,0	2,2	1,6	23,6
AIPC 100 S4	3,2	1500	77,0	0,80		6,0	2,0	2,2	1,6	25,8



5. Electric motors for unit construction pump

Table 6

Designed for rotary, circulation and vortex pump drive.

Motors are equipped with a special tail shaft, depending on pump design. Overall and linkage dimensions are shown in Figure B and Table 6. Electric parameters and masses (for IM 1081 fulfillment) are given in Table 7

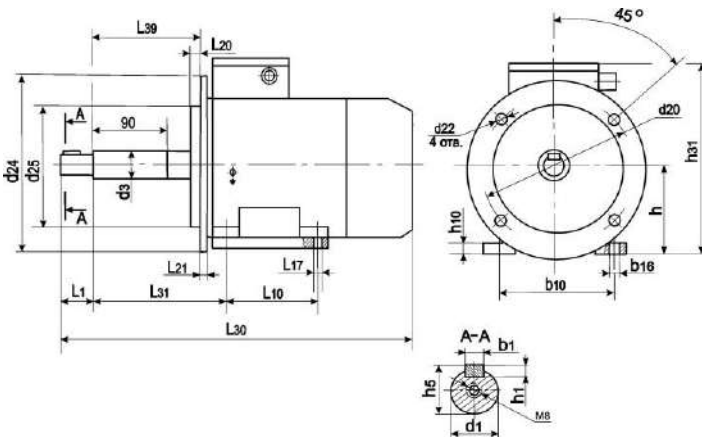

Size index	Standard motor size			
	AIP 80AЖ	AIP 80BЖ	AIP 90Ж	
Overall (maximal)				
L30	392,5	416,5	431,0	
h31	204,5	204,5	224,5	
h37	124,5	124,5	134,5	
Linkage				
L1	28	28	28	
L10	100	100	125	
L17	10	10	10	
L31	168	168	174	
L39	118	118	118	
b10	125	125	140	
b16	12	12	12	
h	80	80	90	
d1	19	19	19	
d3	25	25	25	
d20	IM2081;IM2082 IM3081;IM3082	165	165	215
d22	IM2081;IM2082 IM3081;IM3082	12	12	15
d24	IM2081;IM2082 IM3081;IM3082	200	200	250
d25	IM2081;IM2082 IM3081;IM3082	130	130	180
Reference				
L20	IM2081;IM2082 IM3081;IM3082	3,5	3,5	4,0
L21		10	10	12
b1		6	6	6
h1		6	6	6
h5		21,5	21,5	21,5
h10		9	9	10

Figure B

Table 7

Type	Electric parameters								Mass, kg
	P, kW	Standard rotating frequency, rpm	Coefficient of efficiency, %	cos φ	Iп/Iн	Mп/Mн	Mmax/Mн	Mmin/Mн	
AIP 80 A2Ж	1,5	3000	82,0	0,85	6,5	2,2	2,6	1,8	15,5
AIP 80 B2Ж	2,2	3000	83,0	0,87	6,4	2,1	2,6	1,8	17,5
AIP 80 B4Ж	1,5	1500	78,5	0,80	5,3	2,2	2,4	1,7	16,7
AIP 90 L2Ж	3,0	3000	84,5	0,85	7,0	2,3	2,6	1,7	23,0
AIP 90 L4Ж	2,2	1500	81,0	0,83	6,0	2,0	2,6	2,0	22,3

6. Electric motors for motor-reducers

Designed for indented motor-reducer drive. Motors are produced With special shafts and flanges (figure C and Table 9, sizes for basic modification are given in the numerator, sizes for the variant with shortened tail shaft are given in the denominator)Electrical parameters comply with general-purpose modification

Motors (Table 8)

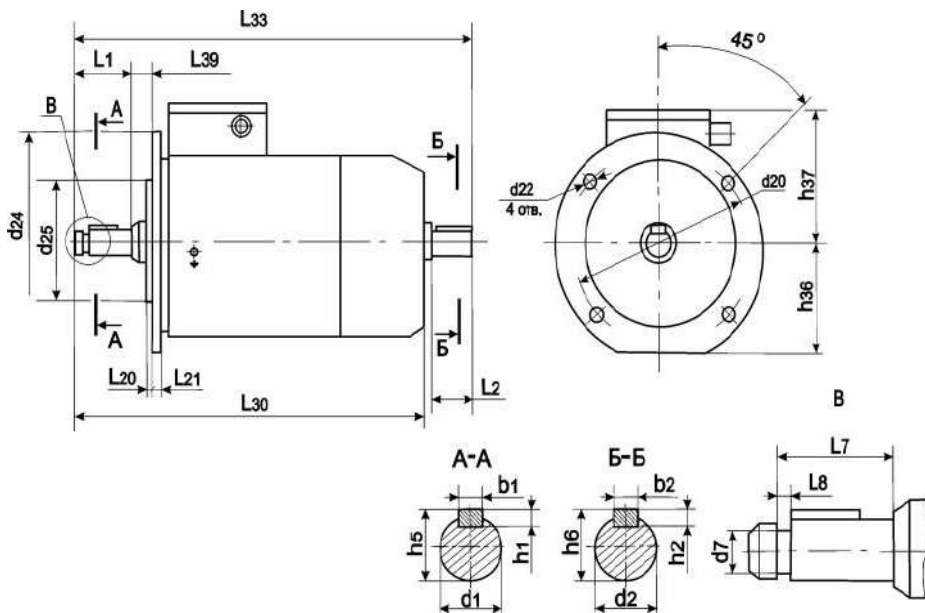

Size index		Standard motor size
		AIP 90P3
Overall (maximal)		
L30		378/ 370
L33		430/422
h36		95
h37		134,5
Linkage		
L1		42/34
L39		18
h		90
d1		16
d2		24
d7		15
d20	IM3021,IM3022 IM3031,IM3032	200
d22	IM3021,IM3022 IM3031,IM3032	11
d24	IM3021,IM3022 IM3031,IM3032	220
d25	IM3021,IM3022 IM3031,IM3032	130
Reference		
L20	IM3021,IM3022 IM3031,IM3032	3,5
L2		50
L7		39/31
L8		1,4
L21		12
b1		4
b2		8
h1		4
h2		7
h5		17,5
h6		27

Table 9

Type	Electric parameters								Mass, kg
	P, kW	Standard rotating frequency, rpm	Coefficient of efficiency, %	cos φ	In/In	Mп/Мн	Mmax/ Мн	Mmin/ Мн	
AIP 90 L2 P3	3,0	3000	84,5	0,85	7,0	2,3	2,6	1,7	22,2
AIP 90 L4 P3	2,2	1500	81,0	0,83	6,0	2,0	2,6	2,0	20,9
AIP 90 L6 P3	1,5	1000	76,0	0,72	5,0	2,0	2,3	1,9	21,9
AIP 90 LA8 P3	0,75	750	72,5	0,71	4,0	1,5	2,0	1,5	20,7
AIP 90 LB8 P3	1,1	750	76,0	0,72	4,5	1,5	2,2	1,5	24,2

Electric motors for axial-flow fan drive at livestock houses and poultry enterprises («birdhouses»)

The motors are intended for installation in microclimate control systems in poultry and livestock buildings and designed to operate in environments with high content of sulfur dioxide, hydrogen sulfide, ammonia, hydrogen chloride. They are installed on braces in the exhaust chimney of ventilation and heating system with an axial-flow fan on the end of a shaft.

The e-motors are rated at IP55. Overall, installation and mounting dimensions are shown in Figure D. Electric parameters and masses are given in Table 10

Table 10

Type	Electric parameters								Mass, kg
	P, kW	Standard rotating frequency, rpm	Coefficient of efficiency, %	cos φ	I _n /I _H	M _n /M _H	M _{max} /M _H	M _{min} /M _H	
АИРП 80А6	0,37	1000	67,5	0,78	4,0	1,4	1,8	-	11,0
АИРП 80В6	1,1	1000	75,0	0,74	4,5	2,2	2,3	1,8	16,8
АИРП 80С6	0,75	1000	71,0	0,71	4,0	2,1	2,2	1,6	12,2
АИРП2П80А6	0,37	1000	61,1	0,76	4,0	1,4	1,8	-	11,0

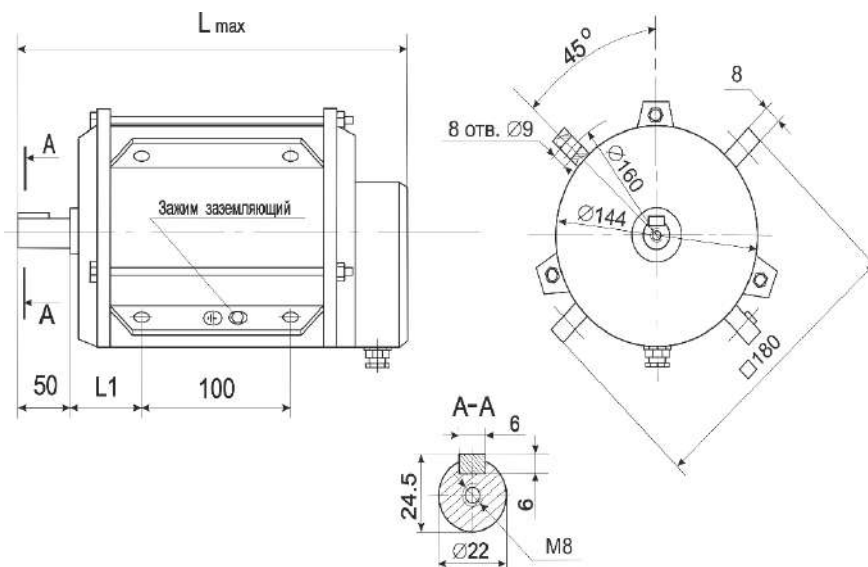

Figure D

АИРП 80 (IM9241)

Type	L, мм	L1, мм
АИРП 80А6	275	50
АИРП 80С6	285	50
АИРП 80В6	315	68

Table 10A

5.8. Motors for railroad electric point machines

The e-motors are designed for electric railway turnout point machines. Design requirements: a three-phase induction motor with a squirrel-cage rotor, mounting position IM9242, climatic version Y2, IP code is IP54. Dimensions of the motors are shown in Figure E. Electrical parameters and weights are shown in table 11.

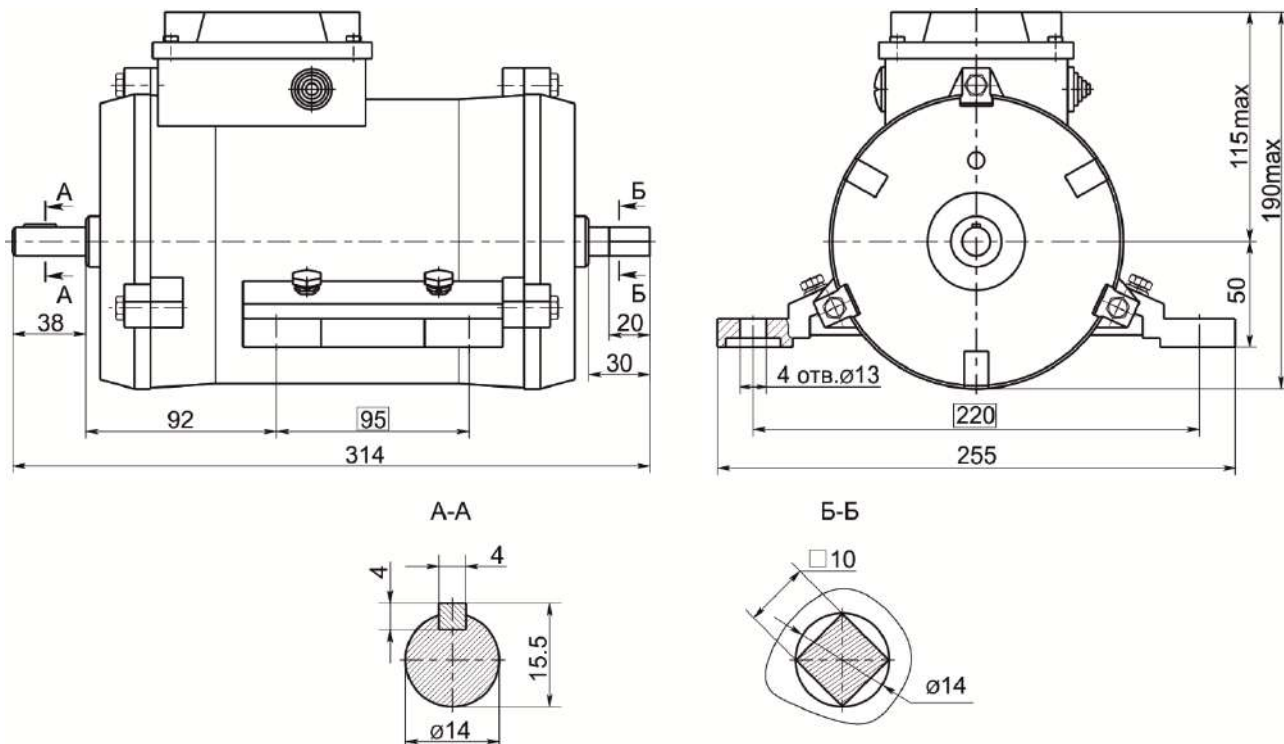

Motors AIP480B4, B6 IM 9242

Table 11

Electric parameters									Mass, kg
Type	P, kW	Coefficient of efficiency, %	cos φ	Slip,%	Mп/Мн	Mmax/Мн	Mmin/Мн	Iп/Iн	
rotating frequency, 1500 rpm									
AIP480B4	0,55	78,0	0,69	7,0	4,8	5,8	4,5	6,5	14,0
rotating frequency, 1000 rpm									
AIP480B6	0,3	66,0	0,72	15,0	2,0	2,2	1,8	4,5	16,0



ingle-phase electric motors

Designed for electric drives of various household machinery (woodworkers, pumps, compressors, etc.) and household labor-saving devices (food choppers, concrete mixing machine, etc.).

Power supply: ac network 220 V.

Motors are produced with an in-built compact working condenser.

Single-phase motors are produced in the same mounting modifications, as basic motors of AIP series and comply with them by linkage dimensions.

Motor sizes are given in Figure A and Table 1

Basic electric parameters and masses (for IM1081 fulfillment) are given in Table 12

Table 12

Type	Electric parameters								Mass, kg	
	P, kW	Standard rotating frequency, rpm	Coefficient of efficiency, %	cos φ	I _п /I _н	M _п /M _н	M _{max} /M _н	C		
								МКF		B
АИРЕ 71 А2	0,55	3000	75,0	0,90	4,3	0,5	2,0	20	450	10,2
АИРЕ 71 В2	0,75	3000	71,0	0,90	4,0	0,55	1,9	25		10,5
АИРЕ 71 С2	1,1	3000	70,0	0,90	3,8	0,55	2,0	30		10,8
АИРЕ 71 А4	0,37	1500	64,0	0,90	3,0	0,6	2,0	12		9,7
АИРЕ 71 В4	0,55	1500	69,0	0,90	3,0	0,6	1,8	16		10,2
АИРЕ 71 С4	0,75	1500	65,0	0,89	3,0	0,45	1,6	18		10,6
АИРЕ 80 А2	1,1	3000	70,0	0,90	3,8	0,55	2,0	25		13,3
АИРЕ 80 В2	1,5	3000	76,0	0,95	4,0	0,45	1,9	40		15,9
АИРЕ 80 С2	1,9	3000	75,0	0,95	4,0	0,45	1,9	40		16,5
АИРЕ 80 D2	2,2	3000	74,0	0,95	4,0	0,45	1,9	50		18,0
АИРЕ 80 А4	0,75	1500	64,0	0,88	3,0	0,55	1,8	30		12,8
АИРЕ 80 В4	1,1	1500	71,0	0,95	2,8	0,45	1,8	30		14,7
АИРЕ 80 С4	1,5	1500	71,0	0,95	2,8	0,45	1,6	35		16,7
АИРЕ 90 L2	2,2	3000	76,0	0,92	3,4	0,45	1,9	60		20,6
АИРЕ 90 L4	1,5	1500	71	0,95	2,8	0,45	1,6	40		19,7



.ADD-IN MOTORS

Motors are designed for machinery integration and represent a wired stator center hub and a rotor center hub, with unprocessed external diameter. Basic sizes are given in Figure F and Table 13. Electrical parameters comply with those of basic modification motors.

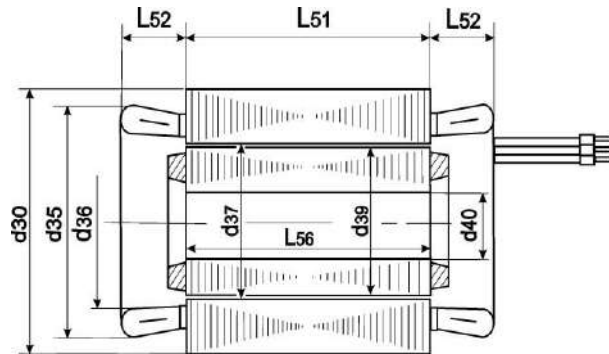

Figure F

Table 13

Type	Sizes,mm																
	d30	d35	d36	d37	d39	d40	L51	L52	L56	Mass,kg							
1	2	3	4	5	6	7	8	9	10	11							
АИРВ 71А2	118	110	72	68	67,5	25	68	42	68	5,8							
АИРВЕ 71А2								40									
АИРВ 71В2								42									
АИРВЕ 71В2								40									
АИРВЕ 71С2								36									
АИРВ 71А4								42									
АИРВЕ 71А4			40														
АИРВ 71В4			42														
АИРВЕ 71В4			40														
АИРВ 71А6			65	35	65	77,5	90	90	35	65	4,7						
АИРВ 71В6			90		90					6,4							
АИРВ 80А2			131	124	76	73	72,4	30	78	45	78	8,4					
АИРВ С80А2	102																
АИРВЕ 80А2		110															
АИРВ 80В2										40							
АИРВ С80В2													102				
АИРВЕ 80В2		110															
АИРВЕ 80С2		122															
АИРВЕ 80Д2	40																
АИРВ 80А4	98	44								90			86	85,5	98	44	98
АИРВ С80А4					40												
АИРВЕ 80А4						40											
АИРВ 80В4		40															
АИРВ С80В4							122										
АИРВ Е80В4						78											
АИРВЕ 80С4	122																
АИРВ 80А6	78	38			93		89	88,5	115		38	78				7,8	
АИРВ С80А6						115											
АИРВ 80В6										115							



АИРВ С80В6												
АИРВ 90В2	149	142,5	86	82	81,5	35	130	40	130	16,5		
АИРВ 90А2							100	49	100	13,3		
АИРВЕ 90А2							130	40	130	16,3		
АИРВ С90А2			100	47	100		12,5					
АИРВ 90В4			104	100	99,5		13,4					
АИРВ 90А4			108	104,1	103,6		100	37,5	100	11,8		
АИРВЕ 90А4							130		130	15,1		
АИРВ С90А4			100	96	95,5		110	45	120	14,9		
АИРВ 90А6							120	42	120	13,8		
АИРВ С90А6			104	100	99,5		110	40	110	13,5		
АИРВ 90А8			100	96	95,5		130		130	130	16,4	
АИРВ С90А8								104				100
АИРВ 90В8			100	96	95,5		130		130	130	16,2	
АИРВ С90В8								104				100
АИРВ 90А4/2			176	160	99		95		94,0	112	60	
АИРВ 90А6/4								176				160
АИРВ 90А8/4	176	160	99	95	94,0	112	60		112	20,3		
АИРВ 100А2								176			160	99
АИРВ С100А2	176	160	99	95	94,0	112	60		112	20,3		
АИРВ 100А4								176			160	99
АИРВС 100А4	176	160	99	95	94,0	112	60		112	20,3		
АИРВ 100В4								176			160	99
АИРВ 100В6	176	160	99	95	94,0	112	60		112	20,3		
АИРВ 100А8/4								176			160	99
АИРВ 100А6/4	176	160	99	95	94,0	112	60		112	20,3		
АИРВ 10В2								176			160	99

Table 14

6 Asynchronous electrical motors of AIS series

Motors have binding of power capacity to linkage
 Dimensions according to CENELEC- DOCUMENT 28/64 standards and DIN42673, DIN 42677 standards)
 Overall and linkage dimensions are shown in Figure G and Table 14. Basic electric parameters and Masses (for IM1081 fulfillment) are given in Tables 14, 15

Figure G

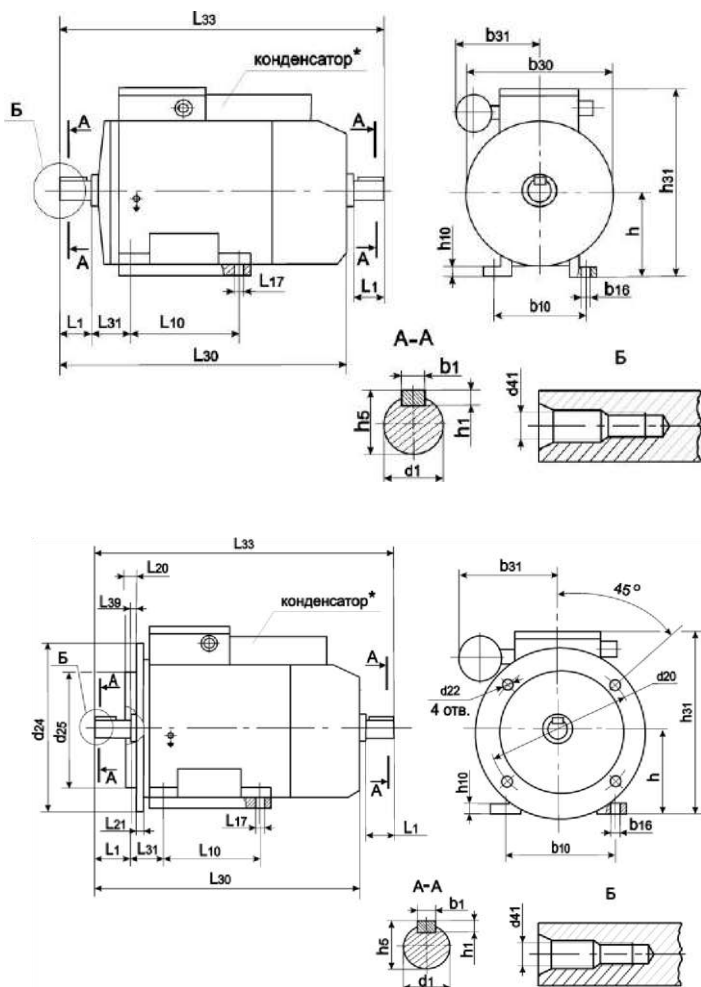

Size index	Standard motor size			
	90 S АИ С	90 L А И АИ СЕ	10 АИ С	
Overall (maximal)				
L30	296,5	320,5	347	
L33	350	374	410	
b30	180	180	200	
b31	115	115	—	
h31	214,5	214,5	240	
h37	124,5	124,5	140	
Linkage				
L1	50	50	60	
L10	100	125	140	
L17	10	10	12	
L31	56	56	63	
b10	140	140	160	
b16	14	14	16	
h	90	90	100	
d1	24	24	28	
d41	M8	M8	M10	
d2 n	IM2081,IM2082 IM3081,IM3082	165	165	165
	IM2181,IM2182 IM3681,IM3682	115;130	115;130	130;165
d2 γ	IM2081;IM2082 IM3081;IM3082	12	12	12
	IM2181;IM2182 IM3681;IM3682	M8;M8	M8;M8	M8;M10
d2 λ	IM2081;IM2082 IM3081;IM3082	200	200	250
	IM2181;IM2182 IM3681;IM3682	140;160	140;160	160;200
d2 ρ	IM2081;IM2082 IM3081;IM3082	130	130	180
	IM2181;IM2182 IM3681;IM3682	95;110	95;110	110;130
Reference				
L2 n	IM2081,IM2082 IM3081,IM3082	3,5	3,5	4,0
	IM2181,IM2182 IM3681,IM3682	3,0; 3,5	3,0; 3,5	3,5; 4,0
L21		10	10	12
b1		8	8	8
h1		7	7	7
h5		27,0	27,0	31,0
h10		10	10	12



* for single-phase motors only)

Table 15

Type	Electric parameters								Mass,kg
	P, kW	Standard rotating frequency, rpm	Coefficient of efficiency, %	cos φ	I _n /I _H	M _n /M _H	M _{max} /M _H	M _{min} /M _H	
AIC 90 S2	1,5	3000	82,0	0,85	6,5	2,2	2,6	1,8	13,4
AIC 90 L2	2,2	3000	83,0	0,87	6,4	2,1	2,6	1,8	16,0
AIC 90 S4	1,1	1500	75,0	0,81	5,0	2,2	2,4	1,7	12,9
AIC 90 L4	1,5	1500	78,5	0,80	5,3	2,2	2,4	1,7	14,8
AIC 90 S6	0,75	1000	71,0	0,63	4,0	2,1	2,2	1,6	12,6
AIC 90 L6	1,1	1000	75,0	0,74	4,5	2,2	2,3	1,8	16,3
AIC 90 S8	0,37	750	63,5	0,59	3,5	2,0	2,3	1,4	14,8
AIC 90 L8	0,55	750	65,0	0,60	3,5	2,0	2,1	1,4	16,0
AIC 100 L2	3,0	3000	84,5	0,85	7,0	2,3	2,6	1,7	20,8
AIC 100 LB2	4,0	3000	86,5	0,86	7,5	2,0	2,4	1,6	23,6
AIC 100 LA4	2,2	1500	81,0	0,83	6,0	2,0	2,6	2,0	20,4
AIC 100 LB4	3,0	1500	81,0	0,81	6,5	2,0	2,4	1,7	25,8
AIC 100 L6	1,5	1000	76,0	0,72	5,0	2,0	2,3	1,9	20,8
AIC 100 LA8	0,75	750	72,5	0,71	4,0	1,5	2,0	1,5	20,5
AIC 100 LB8	1,1	750	76,0	0,72	4,5	1,5	2,2	1,5	24
AIC 90 S4/2	1,12	1500	74,0	0,78	5,0	1,9	2,2	1,6	13,2
	1,5	3000	73,0	0,85	5,0	1,9	2,0	1,5	
AIC 100 L4/2	2,2	1500	79,0	0,83	6,0	1,9	2,4	1,6	21,5
	2,65	3000	78,0	0,86	6,0	2,0	2,4	1,5	
AIC 100 L6/4	1,32	1000	74,0	0,68	5,0	2,3	2,5	1,5	22,2
	1,6	1500	74,0	0,85	5,5	1,6	2,1	1,2	
AIC 100 L8/4	0,8	750	62,0	0,55	3,0	1,7	2,0	1,6	21.1
	1,32	1500	75,0	0,84	5,0	1,5	2,0	1,3	



7. AIBP-series explosion-proof induction motors

AIBP-series explosion-proof e-motors are made in a cast-iron housing (casing). Explosion protection rate is 1ExdIIBT4 GOST 30852.0. According to the level of explosion protection they are intrinsically safe for IIA, IIB category of explosion mixtures. The motors are powered from industrial grid power frequency of 50Hz and are designed to be used for motor-driven mechanisms of external and internal installations of dangerously explosive types of production of chemical, gas, oil refinery and others allied industries where mixtures of flammable gases, vapors and air may occur.

The nominal values of the motors' main parameters (voltage is 380V, frequency is 50Hz) are shown in Table 16.

Table 16

Type	P, kW	Standard rotating frequency, rpm	Coefficient of efficiency, %	cos φ	slip, %	Mп/Мн	Mmax/Мн	Mmin/Мн	Iп/In	Mass,kg
1	2	3	4	5	6	7	8	9	10	11
AIBP 80A2	1,5	3000	82,0	0,85	4,0	2,2	2,6	1,8	6,5	25,8
AIBP 80A4	1,1	1500	76,5	0,77	5,5	2,2	2,4	1,7	5,0	25,3
AIBP 80A6	0,75	1000	71,0	0,71	7,5	2,1	2,2	1,6	4,0	25,0
AIBP 80B2	2,2	3000	83,0	0,87	4,5	2,1	2,6	1,8	6,4	28,4
AIBP 80B4	1,5	1500	78,5	0,80	6,0	2,2	2,4	1,7	5,3	27,2
AIBP 80B6	1,1	1000	75,0	0,74	7,5	2,2	2,3	1,8	4,5	28,7
AIBP 90L2	3,0	3000	84,5	0,88	4,5	2,3	2,6	1,7	7,0	37,7
AIBP 90LB2	4,0	3000	86,5	0,86	5,0	2,0	2,4	1,6	7,5	40,5
AIBP 90LA4	2,0	1500	81,0	0,83	5,0	2,0	2,6	2,0	6,0	36,5
AIBP 90L4	2,2	1500	81,0	0,83	5,0	2,0	2,6	2,0	6,0	36,5
AIBP 90LB4	3,0	1500	81,0	0,81	6,0	2,0	2,4	1,7	6,5	40,9
AIBP 90L6	1,5	1000	76,0	0,72	6,5	2,0	2,3	1,9	5,0	37,1
AIBP 90LA8	0,75	750	72,5	0,71	6,0	1,5	2,0	1,5	4,0	36,3
AIBP 90LB8	1,1	750	76,0	0,72	5,0	1,5	2,2	1,5	4,5	39,1



АИВР 90Л4/2	2,2/2,65	1500/3000	79,0/78,0	0,83/0,86	5,0	1,9/2,0	2,4	1,6/1,5	6,0	38,1
АИВР 90Л6/4	1,32/1,6	1000/1500	74,0	0,68/0,85	5,0	2,3/1,6	2,5/2,1	1,5/1,2	5,0/5,5	38,8
АИВР 90Л8/4	0,8/1,32	750/1500	62,0/75,0	0,60/0,86	5,5/6,0	1,7/1,5	2,0	1,6/1,3	3,0/5,0	37,7
АИВР 100S2	4,0	3000	86,5	0,86	5,0	2,0	2,4	1,6	7,5	
АИВР 100S4	3,0	1500	81,0	0,81	6,0	2,0	2,4	1,7	6,5	

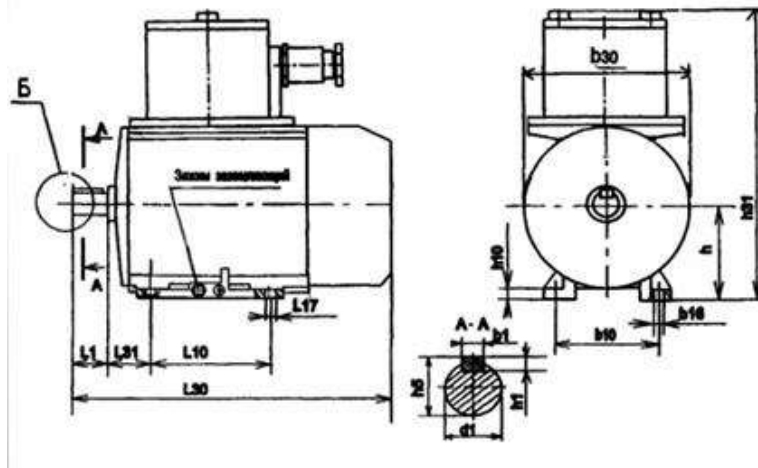

Figure H

Table 17

Size index		Standard motor size		
		АИВР 80	АИВР 90	АИВР 100
Overall (maximal)				
L30		335	357	405
b30		175	200	200
h31		265	283	295
h37		185	193	195
Linkage				
L1		50	50	60
L10		100	125	112
L17		10	10	12
L31		50	56	63
L39		0	0	0
b10		125	140	160
b16		10	10	12
h		80	90	100
d1		22	24	28
d20:	IM2081, IM3041	165	215	215
	IM2181, IM3641	100; 115; 130	115; 130	—
d22:	IM2081, IM3041	12	15	15



	IM2181, IM3641	M6; M8; M8	M8	–
d24:	IM2081, IM3041	200	250	250
	IM2181, IM3641	146; 146; 160	140; 164	–
d25:	IM2081, IM3041	130	180	180
	IM2181, IM3641	80; 95; 100	95; 110	–
Reference				
L20:	IM2081, IM3041	3,5	4,0	4,0
	IM2181, IM3641	3,0; 3,0; 3,5	3,0; 3,5	-
L21		10	12	12
b1		6	8	8
h1		6	7	7
h5		24,5	27,0	31,0



h10	9	10	12
-----	---	----	----

Tel:+ 375 1647 27809 reception

Tel:+ 375 1647 27848 head of commercial department sales department

Tel./Fax:+ 375 1647 48450 marketing department

E-mail: polesie-market@rotor.brest.by